



Delhi Public School, Howrah

Periodic Assessment- 1 (2024-25)

Class-VIII

Care must be taken not to write anything on the question paper. All the questions must be attempted in the correct sequence.

Subject: - Mathematics

Time: 1 Hour 30 minutes

Maximum Marks: 40

General Instructions:

1. This Question Paper has five sections A, B, C, D and E.
2. Section A has 10 MCQs carrying 1 mark each.
3. Section B has 4 questions carrying 2 marks each.
4. Section C has 3 questions carrying 3 marks each.
5. Section D comprises a question in which the subparts carry values of 1 mark each, resulting in a total of 5 marks.
6. Section E has 2 case based integrated units of assessment (04 marks each) with sub-parts of the values of 1, 2 and 1 marks each respectively.
7. All Questions are compulsory. However, an internal choice has been provided in the 2 marks questions of Section E.

SECTION A

Section A consists of 10 questions of 1 mark each

DIRECTION: In the question number 1 to 6, there are four choices (a), (b), (c) and (d) out of which **ONLY ONE** is correct.

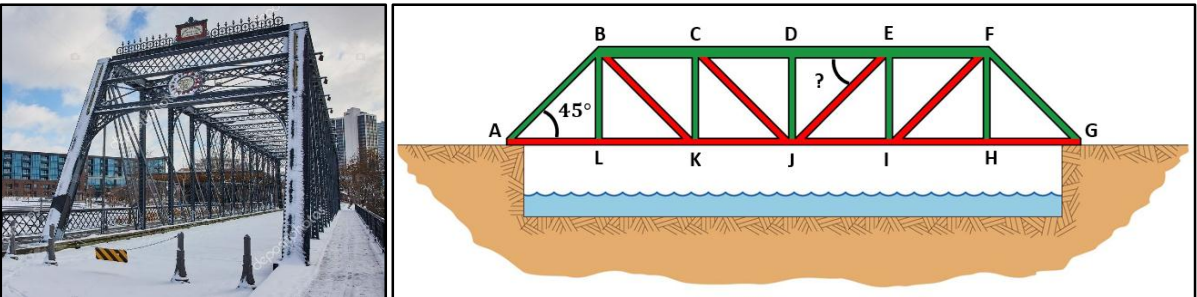
1.	 <p>A railroad bridge which is in the shape of trapezium is known as Truss Bridge. In the given figure, $ABFG$ is a trapezium shaped Truss Bridge and $\overline{AB} \parallel \overline{EJ}$. If $\angle LAB = 45^\circ$, then find the angle $\angle DEJ$.</p> <p>(a) 135° (b) 45° (c) 60° (d) 105°</p>	1
2.	<p>A bag has 3 red balls & 5 green balls. If a person takes any ball from the bag, then what is the probability of getting only a red ball?</p> <p>(a) $\frac{5}{8}$ (b) $\frac{1}{8}$ (c) $\frac{7}{8}$ (d) $\frac{3}{8}$</p>	1
3.	<p>For the equation given below, a number is hidden behind the grey box. Piyush was told that the solution of the equation is an integer.</p> $17z + 5 = 9z + \blacksquare$ <p>Choose from the following options, what could be the hidden number.</p> <p>(a) 13 (b) 0 (c) 1 (d) 3</p>	1

4. A student is trying to simplify the following expression using properties of rational numbers: 1

$$\frac{2}{7} + \frac{1}{2} \times \frac{4}{5} + \frac{1}{2} \times \frac{2}{5} + \frac{3}{14} + \frac{7}{5}$$

He realizes that he can rearrange these rational numbers to make the problem easier as follows:

$\frac{2}{7} + \frac{1}{2} \times \frac{4}{5} + \frac{1}{2} \times \frac{2}{5} + \frac{3}{14} + \frac{7}{5}$ $= \frac{2}{7} + \frac{1}{2} \times \left(\frac{4}{5} + \frac{2}{5} \right) + \frac{3}{14} + \frac{7}{5} \quad \text{(1)}$ $= \frac{2}{7} + \frac{1}{2} \times \frac{6}{5} + \frac{3}{14} + \frac{7}{5}$ $= \frac{2}{7} + \frac{3}{5} + \frac{3}{14} + \frac{7}{5}$ $= \frac{2}{7} + \frac{3}{14} + \frac{3}{5} + \frac{7}{5} \quad \text{(2)}$ $= \left(\frac{2}{7} + \frac{3}{14} \right) + \left(\frac{3}{5} + \frac{7}{5} \right)$ $= \frac{7}{14} + \frac{10}{5}$ $= \frac{1}{2} + 2$ $= \frac{5}{2}$	
--	--

Which of the following properties, the student had used in (1) and (2) to solve the problem?

- (a) (1) Associativity, (2) Commutativity (b) (1) Distributivity, (2) Commutativity
 (c) (1) Associativity, (2) Distributivity (d) (1) Commutativity, (2) Distributivity

5. 1

One pair of parallel sides	Trapezium	Two pairs of parallel sides	Parallelogram	No pair of parallel sides	?
----------------------------	-----------	-----------------------------	---------------	---------------------------	---

Applying the same logic used in first two cases, which option will be there in the place of '?' mark?

- (a) Square (b) Isosceles trapezium (c) Rectangle (d) Kite

6. The pie chart given below shows the result of a survey carried out to find the modes of travel used by the children to go to school. 1

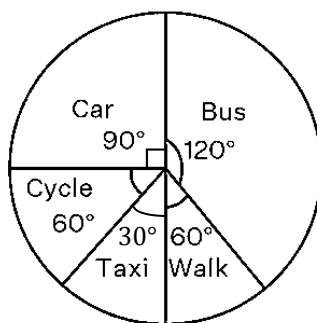

If 72 children took part in the survey, how many children use car to travel to school?

- (a) 18 (b) 36 (c) 12 (d) 24

DIRECTION: In the question numbers 7 and 8, there are four choices (a), (b), (c) and (d) out of which **ONE** or **MORE** may be correct.

7. Choose the options that are linear equations in one variable. 1

- (a) $\frac{7}{3x^2} - 2 = 14$ (b) $\frac{7x-5}{5x+3} = \frac{2}{3}$
 (c) $9z + 13 = 19z + 3$ (d) $5x^2 + 13 - 15x = 1$

8. Ananya, a student of Geography is collecting information about rainfall of the following places. She took the average of one week's data of rainfall provided by the meteorological department as depicted in the table below:

City	SOUTH ANDAMAN	DHUBRI	GOLAGHAT	NICOBAR
Rainfall (mm)	$5\frac{3}{5}$	$7\frac{3}{5}$	$6\frac{2}{5}$	$2\frac{4}{5}$



Based on the above information which of the following Information(s) is true?

- (a) The rainfall of Nicobar is half of the rainfall of south Andaman.
- (b) The rainfall of Golaghat is $\frac{32}{5}$ mm.
- (c) The difference between the rainfall of Dhubri and Golaghat is $\frac{6}{5}$ mm.
- (d) The rainfall of Dhubri is $\frac{38}{5}$ mm.

DIRECTION: In the question numbers 9 and 10, a statement of Assertion (A) is followed by a statement of Reason (R). Choose the correct option.

9. **Assertion (A):** The degree of the equation, $2x + 1 = 3$ is 2.
Reason (R): Standard form of the linear equation in one variable is $ax + b = 0$, where x is a variable and a, b are arbitrary constants.

- (a) Both A and R are true and R is the correct explanation of A.
- (b) Both A and R are true but R is not the correct explanation of A.
- (c) A is true but R is false.
- (d) A is false but R is true.

10. **Assertion (A):** $\frac{-5}{2} \div 0 = \text{undefined}$.
Reason (R): Rational numbers are closed under addition, subtraction, multiplication but not division.

- (a) Both A and R are true and R is the correct explanation of A.
- (b) Both A and R are true but R is not the correct explanation of A.
- (c) A is true but R is false.
- (d) A is false but R is true.

SECTION B

Section B consists of 4 questions of 2 marks each

11. The pie chart given in the figures shows the percentage of users of a particular app in different cities.

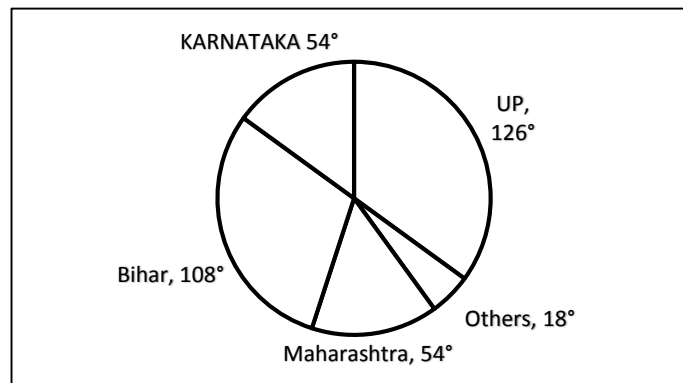

If there are total 15 lakhs users then, how many total numbers of users are there from UP and Bihar?

12. Solve: $\frac{4t}{3} - t = \frac{7}{3} - \frac{2t+4}{3}$

13. Which of the angles marked in the quadrilateral PQRS below are exterior angles?

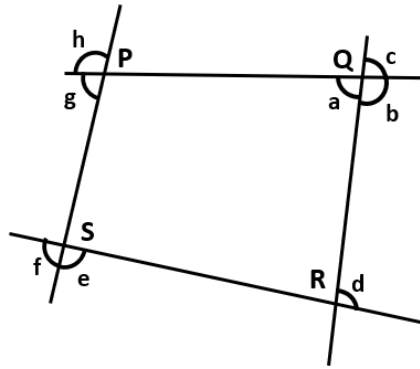

2

14. A survey of 150 families shows the number of girls in each family. Out of these families one is chosen at random. What is the probability that the chosen family has 2 girls?

Number of Girls in the Family	0	1	2
Number of Families	30	115	5

2

SECTION C

Section C consists of 3 questions of 3 marks each

15. Verify: $a \times (b + c) = (a \times b) + (a \times c)$ for

$$a = \frac{3}{4}, b = \frac{-1}{3} \text{ and } c = \frac{5}{6}$$

3

16. ABCD is a quadrilateral with $\angle ADC = 28^\circ$ and $\angle BAD = 62^\circ$. What is the value of x ?

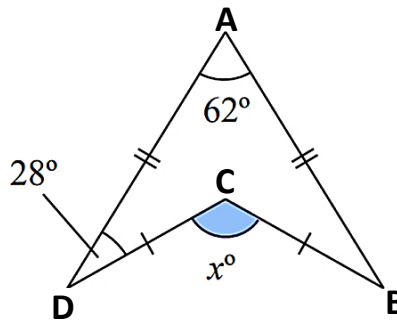

3

17. There are 900 creatures in Alipore Zoological Garden, Kolkata as per the table given below.

Kind of Creatures	Birds	Reptiles	beasts	Water animals	Other land animals
Number of Creatures	125	50	150	175	400

Represent the above data in a pie chart.

3

SECTION D

Section D comprises a question in which the subparts carry values of 1 mark each, resulting in a total of 5 marks.

18. In the Indian Premier League (IPL), the top four teams at the end of the regular season can go for 'eliminator' and 'semi-final' round. In 2024, after the regular matches the teams SRH (Sunrisers Hyderabad), RR (Rajasthan Royals), RCB (Royal Challengers Bengaluru) and KKR (Kolkata Knight Riders) achieved the top 4 positions.

The solution of the following linear equations of one variable indicate the position of the teams in the table. Decode the following equations to find the position of each team.



(i) RR: $4(1 - x) + 6 = -2$	1
(ii) KKR: $3x - 8 - x + 7 - x + 8 = 8$	1
(iii) RCB: $x - \frac{7}{2} = \frac{1}{2}$	1
(iv) SRH: $\frac{3x-6}{2x-4} = \frac{5}{2}$	1
(v) What is the highest power of the variable appearing in linear equation in one variable?	1

SECTION E

Section E has 2 case based integrated units of assessment (04 marks each) with sub-parts of the values of 1, 2 and 1 marks each respectively.

19. Aditya and Suvam both work in a multinational company. They both earn ₹1,50,000 per month. Their monthly expenses and savings are shown through the diagram given below.

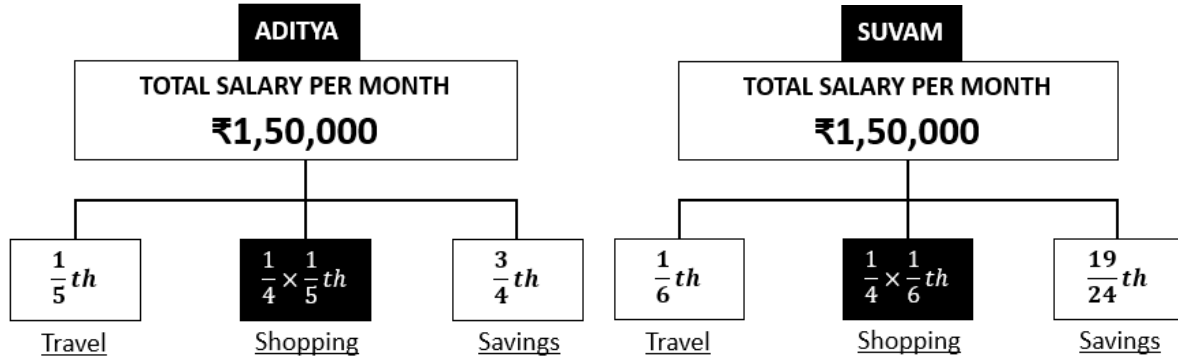

Based on the above information, answer the following questions.

- | | |
|---|---|
| (i) Who saves more amount after their expenses? | 1 |
| (ii) (a) Find the total amount spent by Aditya and Suvam on shopping using the distributive property of multiplication over addition. | 2 |
| [OR] | |
| (b) Find the total amount spent by Aditya and Suvam on travel expenses. | |
| (iii) Is subtraction of rational numbers commutative? | 1 |

20. During Mathematics Lab activity, each student was given four straws of length 8 cm, 8cm, 6 cm and 6 cm to make different types of quadrilaterals. One of student made a quadrilateral $ABCD$ in which $AB = CD = 8$ cm and $AD = BC = 6$ cm as shown in the figure.

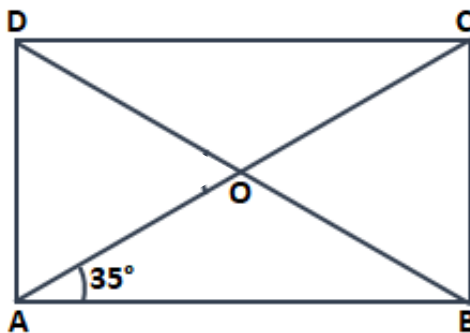

Based on the above information, answer the following questions.

- | | |
|---|---|
| (i) Find the value of x if $AO = 2x - 5$ and $CO = 5$. | 1 |
| (ii) (a) In the given rectangle $ABCD$ with $\angle OAB = 35^\circ$. Find $\angle AOD$. | 2 |

[OR]

(b) If the diagonal extended outside to the point E, then find $\angle ECB$.

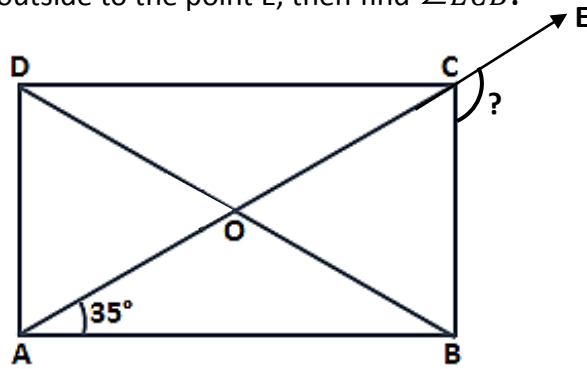

(iii) Can parallelogram and kite be drawn using these straws?

1
